

USN

--	--	--	--	--	--	--	--	--	--

06AL51

**Fifth Semester B.E. Degree Examination, June/July 2011**  
**Management and Entrepreneurship**

Time: 3 hrs.

Max. Marks:100

**Note: Answer any FIVE full questions choosing  
at least TWO questions from each part.**

**PART – A**

- 1 a. According to Mintzberg, what are the different roles of a manager when he occupy different positions in different situations. Explain in brief. (10 Marks)
- b. Using characteristic of profession as given by McFarland, discuss whether management a profession. (05 Marks)
- c. List and discuss various contributions F.W, Taylor made in development of management thought. (05 Marks)
- 2 a. What is planning? Discuss importance of planning. (05 Marks)
- b. What is rational decision? Explain the steps involved in it. (07 Marks)
- c. What is the principle of navigational change? Basing this during planning, explain the areas where built in flexibility need to be considered and what would then mean? (08 Marks)
- 3 a. State and explain principles of organization. (10 Marks)
- b. What is span of management? What factors govern the span of management? (05 Marks)
- c. Describe matrix organization. (05 Marks)
- 4 a. What is co-ordination? What are the techniques of achieving effective co-ordination? (08 Marks)
- b. What is motivation? Explain Maslow's need hierarchy theory of motivation. (07 Marks)
- c. Explain principle of effective communication. (05 Marks)

**PART – B**

- 5 a. List classification and types of entrepreneurs. (10 Marks)
- b. List and explain entrepreneurial functions. (05 Marks)
- c. List barriers to entrepreneurship as identified by Karl H Vespar. (05 Marks)
- 6 a. Describe steps for starting a small industry. (10 Marks)
- b. What is small scale industrial unit? What is the importance of SSI? (05 Marks)
- c. Explain the impact of globalization on small scale industries. (05 Marks)
- 7 a. What is prime minister's Rozgar Yojana (PMRY)? What are its salient features? (03 Marks)
- b. What are various activities of TECSOK (Technical Consultancy Services Organisation of Karnataka)? (07 Marks)
- c. What roles government is playing to promote and growth of SSI? Name certain institutions organized to support this cause. (10 Marks)
- 8 a. What is project report? What is the importance of it? (05 Marks)
- b. What do you mean by project feasibility? Discuss about economic feasibility. (05 Marks)
- c. What factors on which a project report is generally prepared? Explain. (10 Marks)

\* \* \* \* \*

**Fifth Semester B.E. Degree Examination, June/July 2011**  
**Design of Machine Elements – I**

Time: 3 hrs.

Max. Marks:100

**Note: 1. Answer FIVE full questions selecting at least TWO questions from each part.**  
**2. Use of design data hand book is permitted.**

**PART – A**

- 1 a. Draw stress – strain diagram for mild steel subjected to tension. Explain the significance of salient points. (06 Marks)
- b. A point in a structural member subjected to plane stress is shown in Fig.Q.1(b). Determine the following :
  - i) Normal and tangential stress intensities on plane MN inclined at  $45^\circ$ .
  - ii) Principal stresses and their direction.
  - iii) Maximum shear stress and the direction of the planes on which it occurs. (14 Marks)

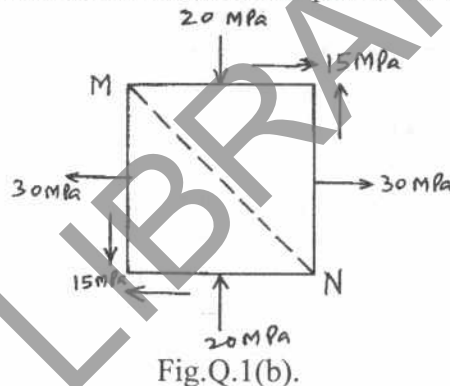

- 2 a. Explain the following theories of failure :
  - i) Maximum normal stress theory.
  - ii) Maximum distortion energy theory. (08 Marks)
- b. An unknown weight falls through 10 mm on a collar rigidly attached to the lower end of a vertical bar 3000 mm long and  $600 \text{ mm}^2$  in section. If the maximum deflection is 2 mm. What is the corresponding stress and the value of unknown weight? Take  $E = 200 \text{ kN/mm}^2$ . (12 Marks)
- 3 a. Derive Goodman's equation. (04 Marks)
- b. Explain cumulative fatigue damage. (04 Marks)
- c. A circular bar of 500 mm length is supported freely at its two ends. It is acted upon by a central concentrated cyclic load having a minimum value of 20 kN and a maximum value of 50 kN. Determine the diameter of bar by taking a factor of safety of 2, size effect of 0.85, surface finish factor of 0.9. The material properties of bar are given by : ultimate strength of 650 MPa, yield strength of 500 MPa and endurance strength of 350 MPa. (12 Marks)
- 4 a. The cylinder head of a steam engine is subjected to a steam pressure of  $0.7 \text{ N/mm}^2$ . It is held in position by means of 12 bolts. A soft copper gasket is used to make the joint leak – proof. The effective diameter of cylinder is 300 mm. Find the size of the bolts so that the stress in the bolts is not to exceed  $100 \text{ N/mm}^2$ . (10 Marks)

- b. Estimate the maximum wrench torque which can be applied in tightening a 20 mm bolt if the shear stress in the body of the bolt is not to exceed  $140 \text{ MN/m}^2$ . Outside bolt diameter = 20 mm, root diameter = 16.72 mm, thread section has  $60^\circ$  included angle ( $\theta = 30^\circ$ ), pitch = 2.5 mm, effective friction radius under nut,  $r_c = 12 \text{ mm}$ , thread and collar friction coefficient estimated at 0.10. (10 Marks)

**PART – B**

- 5 A hoisting drum 0.5 m in diameter is keyed to a shaft which is supported in two bearings and driven through a 12:1 reduction ratio by an electric motor. Determine the power of the driving motor, if the maximum load of 8 kN is hoisted at a speed of 50 m/min and the efficiency of the drive is 80%. Also determine the torque on the drum shaft and the speed of the motor in r.p.m. Determine also the diameter of the shaft made of machinery steel, the working stresses of which are 115 MPa in tension and 50 MPa in shear. The drive gear whose diameter is 450 mm is mounted at the end of the shaft such that it overhangs the nearest bearing by 150 mm. The combined shock and fatigue factors for bending and torsion may be taken as 2 and 1.5 respectively. (20 Marks)
- 6 a. Design a Knuckle joint to transmit 150 kN. The design stresses may be taken as  $75 \text{ N/mm}^2$  in tension,  $60 \text{ N/mm}^2$  in shear and  $150 \text{ N/mm}^2$  in compression. (10 Marks)
- b. A splined connection in an automobile transmission consists of 10 splines cut in a 58 mm diameter shaft. The height of each spline is 5.5 mm and the keyways in the hub are 45 mm long. Determine the power that may be transmitted at 2500 rev/min if the allowable normal pressure on the splines is limited to 4.8 MPa. (10 Marks)
- 7 a. Design a double riveted lap joint with zig-zag riveting for 13 mm thick plates. The working stresses to be used are  $\sigma_t = 80 \text{ MPa}$ ;  $\tau = 60 \text{ MPa}$ ;  $\sigma_c = 120 \text{ MPa}$ . State how the joint will fail and find the efficiency of the joint. (10 Marks)
- b. A bracket carrying a load of 15 kN is to be welded as shown in Fig.Q.7(b). Find the size of the weld required if the allowable shear stress is not to exceed 80 MPa. (10 Marks)

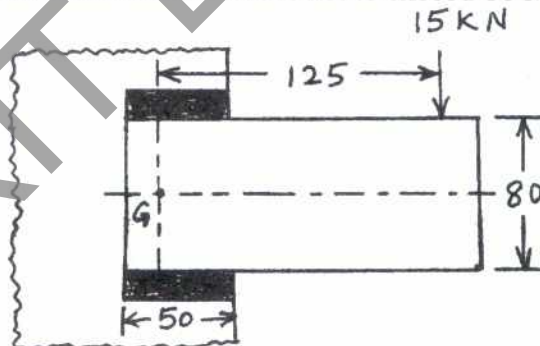

All dimensions in mm.

Fig.Q.7(b).

- 8 a. Derive the equation for maximum efficiency of a square threaded screw. (08 Marks)
- b. The cutter of a broaching machine is pulled by square threaded screw of 55 mm external diameter and 10 mm pitch. The operating nut takes the axial load of 400 N on a flat surface of 60 mm and 90 mm internal and external diameters respectively. If the coefficient of friction is 0.15 for all contact surfaces, determine the power required to rotate the nut when the cutting speed is 6m/min. Also find the efficiency of the screw. (12 Marks)

\* \* \* \* \*

**Fifth Semester B.E. Degree Examination, June/July 2011**  
**Dynamics of Machines**

Time: 3 hrs.

Max. Marks:100

**Note: Answer FIVE full questions selecting  
at least TWO questions from each part.**

**PART - A**

- 1 a. Define equilibrium with respect to two force members and three force members. (04 Marks)  
 b. A four bar mechanism under the action of external force is shown in Fig.Q1(b). Determine the torque  $T_2$  and various forces on links for the equilibrium of the system. (16 Marks)

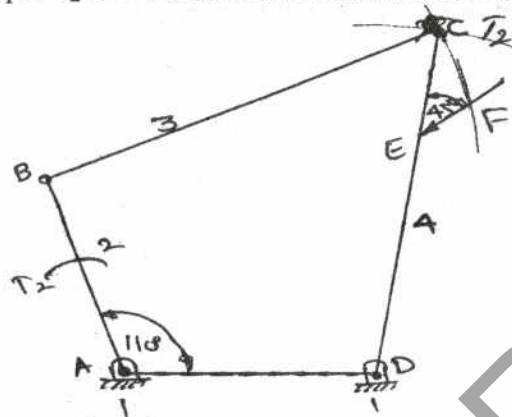

Fig.Q1(b)

 $F = 2000 \text{ N at } 45^\circ \text{ on CD}$ 
 $AB = 200 \text{ mm}$ 
 $AD = 215 \text{ mm}$ 
 $BC = 370 \text{ mm}$ 
 $DC = 350 \text{ mm}$ 
 $CE = 100 \text{ mm}$ 

- 2 a. Derive an expression for 'size of flywheel'. (06 Marks)  
 b. A punching machine is required to punch 5 holes per minute of 50 mm diameter in 40 mm thick plate. The ultimate shear strength of plate material is 225 MPa. The punch has a stroke of 100 mm. Find the power of motor required if mean speed of flywheel is 18 m/s. If coefficient of fluctuation of energy is 4%, find the mass of the flywheel. (14 Marks)
- 3 a. State the laws of dynamic or kinetic friction. (03 Marks)  
 b. Derive an expression for frictional torque in a single collar bearing assuming uniform pressure. (05 Marks)  
 c. An open belt drive connects two pulleys 1.5 m and 0.5m diameter on parallel shafts 3.5m apart. The belt has a mass of 1 kg/m length and the maximum tension in the belt is not to exceed 2 kN. The 1.5m pulley, which is the driver runs at 250 rpm. Due to belt slip, the velocity of the driven shaft is only 730 rpm. If the coefficient of friction between the belt and the pulley is 0.25 find,  
 i) The torque on each shaft    ii) Power transmitted    iii) The power lost in friction and  
 iv) The efficiency of the drive. (12 Marks)
- 4 a. Explain the procedure for balancing several masses rotating in the same plane. (05 Marks)  
 b. Four masses  $M_1 = 100 \text{ kg}$ ,  $M_2 = 175 \text{ kg}$ ,  $M_3 = 200 \text{ kg}$  and  $M_4 = 125 \text{ kg}$  are fixed to the crank of 200 mm radius and revolve in planes 1, 2, 3 and 4 respectively. The angular position of the planes 2, 3 and 4 with respect to first mass are  $75^\circ$ ,  $135^\circ$  and  $240^\circ$  taken in the same sense. Distance of the planes 2, 3 and 4 from first are 600 mm, 1800 mm and 2400 mm. Determine the magnitude and position of the balancing masses at radius 600 mm in planes 'L' and 'M' located in the middle of 1 and 2 and in the middle of 3 and 4 respectively. (15 Marks)

PART – B

- 5 a. Obtain an expression for primary forces for a V engine having two identical cylinders lying in a plane. The included angle between the cylinder centre line is  $22^\circ$ . (06 Marks)
- b. A four crank engine has two outer cranks set at  $120^\circ$  to each other, and their reciprocating masses are each 400 kg. The distance between the planes of rotation of adjacent cranks are 450 mm, 750mm and 600 mm. If the engine is to be in complete primary balance, find the reciprocating mass and the relative angular position for each of the inner cranks. If the length of each crank is 300 mm, length of each connecting rod is 1.2 m and the speed of rotation is 240 rpm, what is the maximum secondary unbalanced force? (14 Marks)
- 6 a. Explain sensitiveness, stability, isochronism and hunting of governor. (08 Marks)
- b. The radius of rotation of the balls of a Hartnell governor is 100 mm at the minimum speed of 300 rpm. Neglecting gravity effect, determine the speed after the sleeve has lifted by 50 mm. Also determine the initial compression of the spring, governor effort and power. Take length of ball arm of lever = 150 mm, length of sleeve arm = 100 mm, weight of each ball = 40 N and stiffness of spring = 25 N/mm. (12 Marks)
- 7 a. Explain with a sketch gyroscope, axis of spin, precession and axis of precession. (06 Marks)
- b. A rear engine automobile is traveling along a track of 100 m mean radius. Each of the four wheels has a moment of inertia of  $2 \text{ kg m}^2$  and an effective diameter of 0.6 m. The rotating parts of the engine have a moment of inertia of  $1.25 \text{ kg m}^2$ . The engine axis is parallel to rear axle and the crank shaft rotates in the same direction as the wheels. The gear ratio of engine to back axle is 3:1. The automobile mass is 1500 kg and the centre of gravity is 0.5m above the road level. The width of track of the vehicle is 1.5m. Determine the limiting speed of the vehicle around the curve for all four wheels to maintain contact with the road surface if it is not banked. (14 Marks)
- 8 a. Derive an expression for velocity and acceleration for circular arc cam with roller follower when the contact is on the flank. (10 Marks)
- b. The particulars of a symmetrical tangent cam operating a roller follower are as follows:  
 Least radius of cam = 30 mm                      Roller radius = 20 mm  
 Angle of ascent =  $75^\circ$                               Total lift = 20 mm  
 Speed of cam shaft = 600 rpm.  
 Calculate i) the principal dimensions of the cam and ii) the equation of the displacement curve when the follower is in contact with straight flank and circular nose. Assume that there is no dwell between the ascent and return. (10 Marks)

\* \* \* \* \*

--	--	--	--	--	--	--	--	--	--

**Fifth Semester B.E. Degree Examination, June/July 2011**

**Energy Engineering**

Time: 3 hrs.

Max. Marks:100

**Note: Answer FIVE full questions, selecting at least TWO questions from each part.**

**PART – A**

- 1
  - a. Explain cyclone furnace. Why they are more suitable for Indian coals? (08 Marks)
  - b. What are all the advantages and disadvantages of pulverized fuel? (06 Marks)
  - c. Describe any two type of ash handling system for coal based steam power plant. (06 Marks)
  
- 2
  - a. What is superheater? State the advantages of superheated steam. (04 Marks)
  - b. Explain Benson boiler with a neat sketch. What are all its advantages and disadvantages? (08 Marks)
  - c. What is the function of air preheater? Explain recuperative air preheater. (04 Marks)
  - d. A chimney is 30m high and the temperature of hot gases inside the chimney is 350°C. If the temperature of outside air is 30°C and furnace is supplied with 15 kg of air/kg of coal burnt, calculate : i) draft in mm of water and ii) draft head in m of hot gases. (04 Marks)
  
- 3
  - a. Draw the schematic diagram of diesel engine power plant and explain the function of essential components. (10 Marks)
  - b. What are all the different methods used for starting diesel engine? (06 Marks)
  - c. What are all the applications of diesel engine in power field? (04 Marks)
  
- 4
  - a. Define hydrograph and unit hydrograph. The data related to particulate site of river for hydro power is measured for the year 2008. The mean monthly discharge for the months from April 2008 to March 2009 in millions of m<sup>3</sup> per month are 25, 10, 75, 125, 150, 120, 100, 75, 75, 50, 40, 30 respectively.
    - i) Draw hydrograph for the given discharges and find the average monthly flow
    - ii) Draw the flow duration curve
    - iii) The power available at mean flow of water if available head is 100 m at the site and the overall efficiency of the generation as 84 percent. Take 30 days in a month. (11 Marks)
  - b. Explain the following terms related to hydro electric power plant :
    - i) Pen stock
    - ii) Water hammer
    - iii) Surge tank. (09 Marks)

**PART – B**

- 5
  - a. Discuss about nuclear fuel used in reactors. What are all the main sources of nuclear waste in nuclear power plant? (08 Marks)
  - b. Draw the schematic of nuclear reactor and explain various components. (06 Marks)
  - c. Compare the merits and demerits of BWR and PWR. (06 Marks)

- 6 a. Calculate the efficiency of two cover solar flat plate collector for the following data :
- Latitude =  $10^{\circ}$  N
  - Day and time = June 1, 12.00 hr
  - Average intensity of solar radiation =  $575 \text{ W/m}^2$
  - Collector tilt =  $30^{\circ}$
  - Heat removal factor = 0.85
  - Transmittance of glass = 0.85
  - Absorptance of glass = 0.90
  - Top loss coefficient for collector =  $7.5 \text{ W/m}^2\text{C}$
  - Ambient temperature =  $30^{\circ}\text{C}$
  - Collector fluid temperature =  $70^{\circ}\text{C}$ . (08 Marks)
- b. Discuss about horizontal axis wind mill with a neat sketch. (06 Marks)
- c. Briefly explain the working of a solar cell. (06 Marks)
- 7 a. List various sources of geothermal energy. Discuss the problems associated with geothermal energy conversion. (06 Marks)
- b. Explain with a neat sketch Rankine cycle OTEC plant. (06 Marks)
- c. Explain with sketches the tidal patterns and working of a tidal plant. (08 Marks)
- 8 a. What is gasification? What are the various types of gasifiers? Explain any one in detail. (10 Marks)
- b. What is anaerobic fermentation? Explain Indian type biogas plant with neat sketch. What are all the factors affecting biogas production? (10 Marks)

\*\*\*\*\*

## Fifth Semester B.E. Degree Examination, June/July 2011

### Turbo Machines

Time: 3 hrs.

Max. Marks:100

- Note: 1. Answer FIVE full questions selecting at least TWO questions from each part.**  
**2. Use of steam tables and Mollier chart permitted.**

#### PART – A

- 1 a. Define a turbo machine. Differentiate between a turbo machine and a positive displacement machine. (08 Marks)
- b. The pressure drop  $\Delta P$  in a pipe depends on the mean velocity of flow  $V$ , length of the pipe  $L$ , diameter of the pipe  $D$ , viscosity  $\mu$ , density of the fluid  $\rho$  and average height of roughness of projection on one side of the pipe surface  $K$ . By using Buckingham's  $\pi$  - theorem, show that  $\Delta P = \rho V^2 \phi \left[ \frac{1}{Re}, \frac{L}{D}, \frac{K}{D} \right]$  where  $Re = \text{Reynold's number}$ . Further prove that the head loss due to friction is given by  $h_f = \frac{fLV^2}{2gD}$  where  $f = \text{friction factor}$  and  $g = \text{acceleration due to gravity}$ . (12 Marks)
- 2 a. Obtain an expression as shown below for energy transfer  $E$  and degree of reaction  $R$  as a function of discharge blade angle  $\beta_2$  for a turbo machine. Make the following assumptions :  
 i)  $u_2 = 2u_1$ , ii) constant radial velocity, iii) no inlet angular momentum and inlet blade angle =  $45^\circ$ . Sketch the nature of variation of  $E$  and  $R$  with respect to  $\beta_2$  as it varies from  $0^\circ$  to  $180^\circ$  and discuss the salient features of the graph.  

$$E = 2V_{f2}^2 (\cot \beta_2 - 2) \quad \text{and} \quad R = \frac{2 + \cot \beta_2}{4}$$
 (12 Marks)
- b. In a mixed flow turbo machine, fluid enters such that the absolute velocity is axial at inlet and the relative velocity is radial at outlet. What is the degree of reaction and energy input to the fluid if the relative velocity at outlet is same as the tangential blade speed at inlet? The following data may be used : inlet diameter = 8cm, exit diameter = 25cm, speed = 3000rpm, blade angle at inlet =  $45^\circ$ . (08 Marks)
- 3 a. Show that for maximum utilization of an axial flow turbine with  $R = \frac{1}{4}$ , the speed ratio is given by  $\phi = \frac{2}{3} \cos \alpha_1$  where  $\alpha_1 = \text{Nozzle angle at inlet with respect to tangential direction}$ . (06 Marks)
- b. In an axial flow turbine, the discharge blade angles are  $20^\circ$  each for both the stator and the rotor. The steam speed at the exit of the fixed blade is 140 m/s. The ratio  $\frac{V_{a1}}{u}$  is equal to 0.7 at the entry and 0.76 at the exit of the rotor blades. Find :i) inlet rotor blade angle; ii) power developed by the blade ring for a mass flow rate of 2.6 kg/s; iii) degree of reaction. (08 Marks)
- c. Steam leaves the rotating blades as shown in the Fig.Q3(c). Evaluate the absolute velocity in magnitude and direction. (06 Marks)

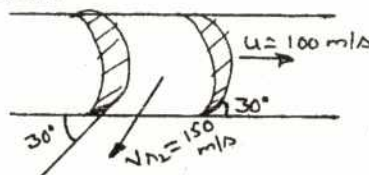

Fig.Q3(c)



- 4 a. For a power generating turbo machine, define :  
 i) total-to-total efficiency      ii) total-to-static efficiency. (04 Marks)
- b. With the help of h-s diagram, show that the preheat factor in a multi stage compressor is less than unity. (08 Marks)
- c. Air flows through an air turbine where its stagnation pressure is reduced in the ratio 5 : 1. The total-to-total efficiency is 80%. The air flow rate is 5 kg/s. If the total power output is 500kW, find : i) inlet total temperature ; ii) actual exit total temperature; iii) actual exit static temperature if the flow velocity is 100 m/s ; iv) total-to-static efficiency. (08 Marks)

### PART – B

- 5 a. Draw the velocity triangles for an axial flow compressor and show that for an axial flow compressor having no axial thrust, the degree of reaction is given by :

$$R = \frac{v_a}{2u} \left[ \frac{\tan \beta_1 + \tan \beta_2}{\tan \beta_1 \tan \beta_2} \right]$$

where  $v_a$  = axial flow velocity,  $u$  = blade speed,  $\beta_1$  and  $\beta_2$  = inlet and outlet blade angles.

(10 Marks)

- b. A centrifugal compressor runs at a speed of 15000 rpm and delivers 30 kg/s of air. The exit diameter is 70cm, relative velocity at exit is 100 m/s at an exit angle of  $75^\circ$ . Assume axial inlet and inlet total temperature = 300K, inlet total pressure = 1 bar. Determine :  
 i) power required to drive the compressor      ii) ideal head developed  
 iii) work done      iv) exit total pressure. (10 Marks)
- 6 a. What is cavitation? What are the causes for cavitation? Explain the steps to be taken to avoid cavitation. (06 Marks)
- b. Derive an expression for the static pressure rise in the impeller of a centrifugal pump with velocity triangles. (06 Marks)
- c. A 4-stage centrifugal pump has impellers each of 38cm diameter and 1.9cm wide at outlet. The outlet vane angle is  $45^\circ$  and the vanes occupy 10% of the outlet area. The manometric efficiency is 85% and overall efficiency is 75%. Determine the head generated by the pump when running at 1000 rpm discharging 60 litres/s. Also determine the power required. (08 Marks)
- 7 a. What is compounding of steam turbine? Explain with the help of a schematic diagram a two row velocity compounded turbine stage. (08 Marks)
- b. Dry saturated steam at 10 bar is supplied to a single rotor axial flow impulse turbine, the condenser pressure being 0.5 bar. The nozzle efficiency is 94% and the nozzle angle at the rotor inlet is  $18^\circ$  to the wheel plane. The rotor blades are equiangular and move at a speed of 450 m/s. If the blade velocity coefficient for the moving blades is 0.92, find :  
 i) The specific power output      ii) Rotor efficiency      iii) Stage efficiency  
 iv) Axial thrust      v) Direction of exit steam velocity. (12 Marks)
- 8 a. Explain the functions of a draft tube in a reaction hydraulic turbine. (04 Marks)
- b. Draw the inlet and outlet velocity triangles for a Pelton wheel. Derive an expression for the maximum hydraulic efficiency of a Pelton wheel in terms of bucket velocity co-efficient and discharge blade angle. (08 Marks)
- c. Two inward flow reaction turbines have the same runner diameter of 0.6m and the same hydraulic efficiency. They work under the same head and they have the same velocity of flow of 6 m/s. One of the runners 'A' revolves at 520 rpm and has an inlet vane angle of  $65^\circ$ . If the other runner 'B' has an inlet vane angle of  $110^\circ$ , at what speed should it run? Assume for both the turbines, the discharge is radial at outlet. (08 Marks)

\*\*\*\*\*

--	--	--	--	--	--	--	--	--	--

**Fifth Semester B.E. Degree Examination, June/July 2011**

**Engineering Economics**

Time: 3 hrs.

Max. Marks:100

**Note: 1. Answer any FIVE full questions, selecting at least TWO questions from each part.**

**2. Use of discrete interest tables is permitted.**

**PART – A**

- 1 a. Differentiate between : i) Intuition and analysis, ii) Tactics and strategy. (08 Marks)
- b. A company 3 years ago borrowed Rs.400000 to pay for a new machine tool, agreeing to repay the loan in 100 monthly payments at an annual nominal interest rate of 12% compounded monthly. The company now wants to pay off the loan. How much would this payment be, assuming no penalty costs for early payout?  
Interest factors :  $(A/P, 1, 100) = 0.01587$  ;  $(P/A, 1, 64) = 47.10277$ . (12 Marks)
- 2 a. Explain the following :  
i) Common multiple method for comparison of assets having unequal lives  
ii) 72 Rule. (08 Marks)
- b. Machine A has a first cost of Rs.90000, no salvage value at the end of its 6 year useful life, and annual operating costs of Rs.50000. Machine B costs Rs.160000 new and has an expected resale value of Rs.40000 at the end of its 9 year economic life. Operating costs for machine B are Rs.40000 per year. Compare the two alternatives on the basis of their present worths, using the repeated projects assumption at 10% annual interest.  
Interest factors :  $(P/F, 10, 5) = 0.56447$ ,  $(P/F, 10, 12) = 0.36863$ ,  $(P/A, 10, 18) = 8.20141$ ,  $(P/F, 10, 9) = 0.42410$ ,  $(P/F, 10, 18) = 0.17986$ . (12 Marks)
- 3 a. Define the following :  
i) Ownership life or service life ii) Accounting life iii) Economic life. (08 Marks)
- b. A company is planning to buy an inspection device (CMM) for Rs.450000. The expected life of the device is 5 years, and the expected annual operating costs and taxes are Rs.6000 for the first year and with an added increase per year of Rs.1000 for years 2 through 5. Maintenance costs will be zero in the first 2 years because of warranty, but are expected to be Rs.10000 in year 3, Rs.15000 in year 4 and Rs.20000 in year 5. What is the minimum desired annual economic benefit of the device, assuming that these benefits will just offset the annual costs? The company uses an interest rate of 10% for economic evaluations.  
Interest factors :  $(A/P, 10, 5) = 0.26380$ ,  $(A/G, 10, 5) = 1.81013$ ,  $(P/F, 10, 3) = 0.75131$ ,  $(P/F, 10, 4) = 0.68301$ ,  $(P/F, 10, 5) = 0.62092$ . (12 Marks)
- 4 a. Explain : i) MARR ii) IRR iii) ERR iv) Depreciation. (08 Marks)
- b. A student has bought a motor cycle whose first cost is Rs.80000 with an estimated life of 5 years. The salvage value of the motor cycle at the end of its life time is Rs.30000. Determine the depreciation amount ( $D_t$ ) and book value ( $B_t$ ) at the end of various years by :  
i) Straight line method  
ii) SOYD method  
iii) Double declining balance method with  $K = \frac{200}{N} \%$ .

Tabulate the values.

(12 Marks)

## PART – B

- 5 a. Explain the objectives of costing. (08 Marks)
- b. Two operators are engaged on forging machine for 25 jobs, each weighing 4kg in a shift of 8 hours. They are paid at the rate of Rs.100 and Rs.80 per day. The forged material costs Rs.3.50 per kg. If the factory and administrative on costs put together are twice the labor cost, find the cost of production per unit. (05 Marks)
- c. A product is manufactured in batches of 100. The direct material cost is Rs.600, the direct labor cost is Rs.750 and the factory overheads are 50% of the prime cost. If the selling expenses are 30% of the factory cost, what would be the selling price of each product so that profit is 15% of the total cost? (07 Marks)
- 6 a. Explain the following terminology as applied to financial statements (give examples) :  
 i) Reserves and surplus  
 ii) Secured loans  
 iii) Current assets. (08 Marks)
- b. The following items are collected from the balance sheet of the company as at 31<sup>st</sup> March 2010. Organize them properly and prepare the balance sheet. (12 Marks)

	Rs.		Rs.
Fixed Assets	5,81,25,000	Provision for dividend	55,25,000
Current liabilities	4,50,50,000	Secured loans	2,50,75,000
Reserves and surplus	4,75,50,000	Debtors	2,65,55,000
Loans and advances	2,51,80,000	Unsecured loans	2,75,50,000
Investments	26,35,000	Stocks	7,70,50,000
Cash and bank balances	65,55,000	Provision for taxation	2,75,000
Share capital	4,50,75,000		

- 7 a. Explain the different financial ratios coming under the broad frame work (category):  
 i) Stability                      ii) Liquidity  
 Also explain the significance of each one. (12 Marks)
- b. Explain the limitations of ratio analysis. (08 Marks)
- 8 a. Describe the essentials of profit planning. (12 Marks)
- b. Explain the advantages and limitations of budgeting. (08 Marks)

\* \* \* \* \*